

# ENCHANTED GARDEN RING FOLIAGE ROYAL



An alternation of yellow gold leaves and gold leaves brushed by hand for a romantic ring set with 7 diamonds.  
7 diamonds: 0.046 carat - White gold (18K Gold = 750/1000): 2.46 g.



## INSPIRATION



In a fairytale garden, the leaves and the branches graciously adorn the whole landscape ... in the heart of this wonderful dream, one imagines them dressed beautifully in the skin of a woman. Hence, the idea of a precious ring inspired by a thin branch delicately sprouting around the finger and placed there for eternity.

## PHASES OF OUR CREATION PROCESS

preliminary steps



prototype adjustment



first fitting





# ECLOSION RING ROSES CROWN



With a crown of sparkling flowers, the petals open up to an eternal diamond heart.  
It can be worn as a standard ring or as a special wedding ring.  
3 diamonds: 0.09 carat - White gold (18K Gold = 750/-): 4.56 g.



## INSPIRATION



The bohemian feel seemed ideal for celebrating romantic nature and femininity. This movement's crown of flowers, emblem of sweetness, freedom and nature were clearly a source of inspiration for our creation team.

## PHASES OF OUR CREATION PROCESS

preliminary steps

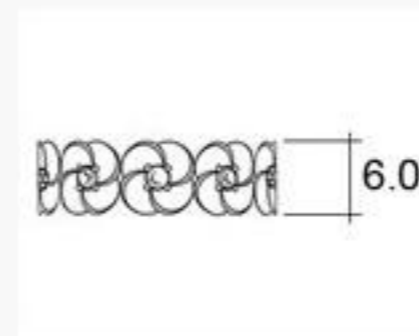

prototype adjustment



first fitting



2.5

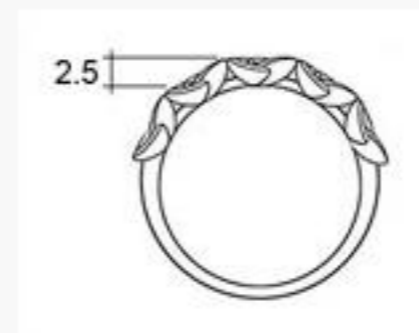



# DESTINY RING BYZANTINE



Shuttle diamonds and shiny diamonds form a romantic and precious fresco.  
 This white gold ring can be a wedding ring or a gift.  
 63 diamonds: 0.686 carat - 6 marquise diamonds: 0.48 carat  
 White gold (18K Gold = 750/1000): 5.66 g.



## INSPIRATION



Strength and gentleness, solidity and romance are apparent contradictions to emanated from this ring which inspired by the palette of qualities a woman has. Thus, in the centre of the ring, the soft round-shaped shuttles aligned in a poetic fresco match with the straight and solid lines that surround them.

## PHASES OF OUR CREATION PROCESS

preliminary steps



prototype adjustment



first fitting

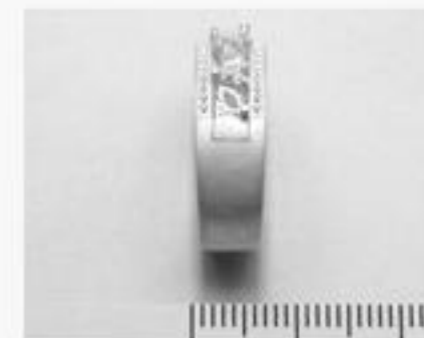
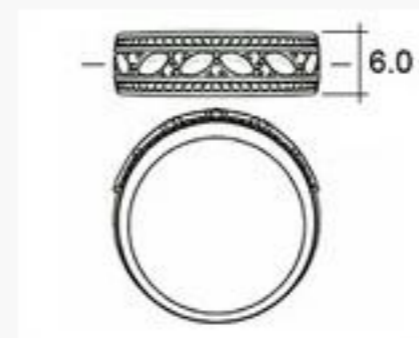



# MYSTERIOUS WOODS RING



A sparkling branch fixed in a timeless state, unable to get a measure of its age: millennial or newly crafted. Its precious leaves, the marquise diamonds, are highlighted by white gold set with brilliants that serve as a cradle. 26 diamonds: 0.372 carat - White gold (9K Gold = 375/-): 1.75 g.



## INSPIRATION



The initial idea was to incarnate a magical totem, a spirit of nature and protector of femininity. The arms of the ring are enclosed and protective branches, the diamond leaves are a representation of freshness and life. In imaginary fairytales, the bearer of this ring is protected by the force of nature, even in the depths of a frightening forest.

## PHASES OF OUR CREATION PROCESS

preliminary steps



prototype adjustment



first fitting





# IMAGINARY WALK RING FAWN DREAMER



A delicate fawn is sleeping on a bed of leaves.  
 Dimensions Fawn: 2.5 cm long, 1.3 cm wide and 1.5 cm high  
 60 diamonds: 0.26 karat - Pink and white gold (18K Gold = 750/1000): 17.2 g.



## INSPIRATION



It is rare and precious to come across a doe at the edge of the woods, even more exceptional to see the frail and delicate fawn. The fawn was an obvious choice to put forth the Edenly animal fairytale. It represents dreams, storytelling, femininity, delicacy and rarity that Edenly wishes to bring to its customers through its environment and its jewelry pieces.

## PHASES OF OUR CREATION PROCESS

choosing your mount



coating art



first piece

